



KONICA MINOLTA

Conforms to JIS A Class and DIN Class C

NEW

CRI Illuminance Meter

CL-70F 1

Easy to use !

Can take spectral measurements of flash light

Good tool for lighting planners

Rotating receptor head



Dark calibration performed without needing cap



Measurement and evaluation of the illuminance, color temperature, and color-rendering index of special illumination sources used for restaurants, museums, studios, and stages, etc.



Easy-to-read display *Display mode examples



Color rendering index



CIE 1931 (CIE 1964)

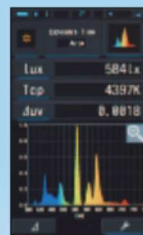

Spectrum

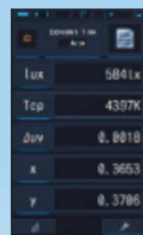

Text

Measurement and evaluation of the illuminance, color-temperature, and color-rendering index of indoor illumination sources such as LEDs, fluorescent lamps, etc.

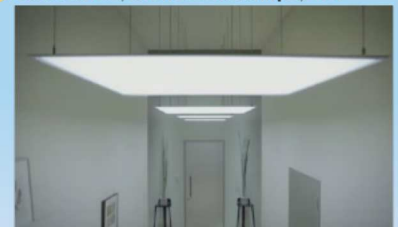

System Diagram

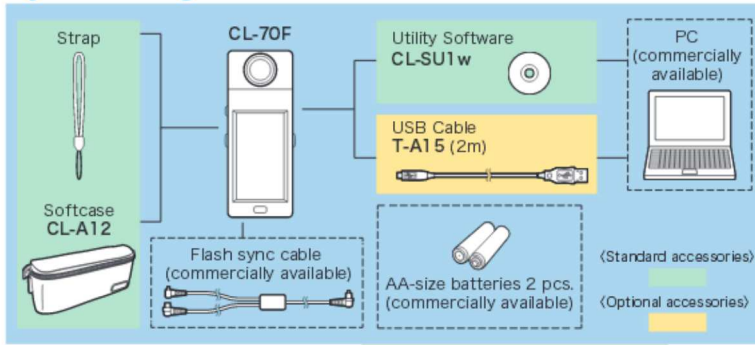

Dimensions (Units: mm)

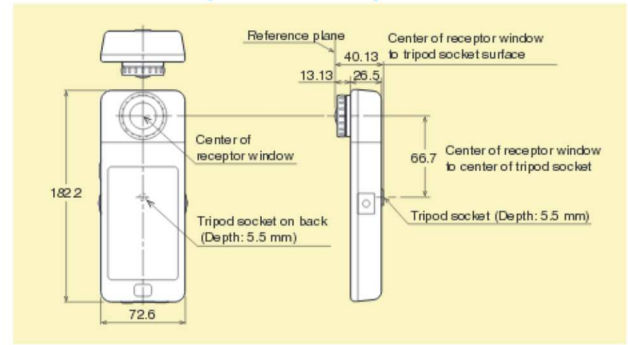

Main Specifications of CL-70F

Model	CRI Illuminance Meter CL-70F
Illuminance meter class	Conforms to requirements for Class A of JIS C1609-1 : 2006 "Illuminance meters Part 1: general measuring instruments; Conforms to DIN 5032 Part 7 Class C
Sensor	CMOS linear image sensor
Spectral wavelength range	380 nm ~ 780 nm
Output wavelength pitch	1 nm
Measuring range	Constant light: 20 to 200,000 lx; 5 to 100,000 K (Chromaticity display requires 5 lx or more) Flash light: 20 to 20,500 lx·s; 2,500 to 100,000 K
Accuracy (Standard Illuminant A) (*1, 2)	E _v : ±5%±1 digit of displayed value xy: ±0.003 (at 800 lx)
Repeatability (Standard Illuminant A) (*1)	E _v : 30 to 200,000 lx: 1%+1digit; 1 to 30 lx: 5%+1digit (*3) xy: 500 to 200,000 lx: 0.001 (*4) xy: 100 to 500 lx: 0.002 (*4) xy: 30 to 100 lx: 0.004 (*4) xy: 5 to 30 lx: 0.008 (*4)
Visible-region relative spectral response characteristics (f1')	Within 9%
Cosine correction characteristics (f2)	Within 6%
Temperature drift (f _t)	E _v : ±5% xy: ±0.006
Humidity drift (f _h)	E _v : ±3% xy: ±0.006
Power	2 AA-size batteries (Alkaline batteries or manganese dry cells); USB bus power
Response time	Constant light (Maximum): 15 sec Constant light (Minimum): 0.5 sec Flash light: 1 ~ 1/500 sec (in 1-step intervals) (*5)
Color indication modes	Correlated color temperature T _{cp} , Difference from blackbody Δuv, XYZ, xy, u'v', Dominant wavelength λ _d , Excitation purity P _e , Spectral irradiance E _v , CRI (Ra, Ri), Peak wavelength λ _p , exposure value
Other functions	Data memory: 999 data; Preset function; Auto power off function
Display languages	English, Japanese, Chinese (Simplified)
Interface	USB 2.0 Mini B
Operation temperature/humidity range	-10 to 40°C, relative humidity of 85% or less (at 35°C) with no condensation
Storage temperature/humidity range	-10 to 45°C, relative humidity of 85% or less (at 35°C) with no condensation
Size	73 (W) × 183 (H) × 27 (D) mm (Not including projecting buttons) D (max): 40 mm
Weight (without battery)	230 g

(*1) Measurement mode: Constant light (range L). Exposure time: AUTO (*4) 10 times measurement (2σ)
(*2) Linear for E_v (*5) Shutter speed
(*3) 10 times measurement (2σ) / Ave

- KONICA MINOLTA and the Konica Minolta logo and the symbol mark, and "Giving Shape to Ideas" are registered trademarks or trademarks of KONICA MINOLTA, Inc.
- The specifications and appearance shown herein are subject to change without notice.
- Screens shown are for illustration purpose only.
- Some lamp control methods may make accurate measurements difficult. For details, please contact your nearest Konica Minolta sales office or dealers.



SAFETY PRECAUTIONS

For correct use and for your safety, be sure to read the instruction manual before using the instrument.

- Be sure to use the specified batteries. Using improper batteries may cause a fire or electric shock.

Utility Software (Standard accessory)

Software	OS	
Windows	Windows® 7 SP1 Windows® 8 Windows® 8.1	Compatible with 32-bit and 64-bit versions of Excel®

* Windows® and Excel® are trademarks of Microsoft Corporation in the USA and other countries.

Konica Minolta's Illuminance Measurement Trio <All conforms to JIS AA Class>

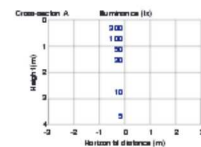
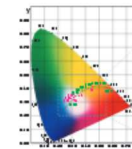
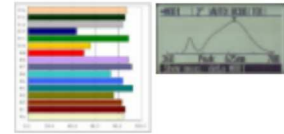

* Both CL-200A and CL-500A also can measure PWM-controlled light.

KONICA MINOLTA, INC.
Konica Minolta Sensing Americas, Inc.
Konica Minolta Sensing Europe B.V.

Osaka, Japan
New Jersey, U.S.A.
European Headquarter / BENELUX
German Office
French Office
UK Office
Italian Office
Swiss Office
Nordic Office
Polish Office
SE Sales Division
Beijing Office
Guangzhou Office
Chongqing Office
Qingdao Office
Wuhan Office

Phone : 888-473-2656 (in USA), 201-236-4300 (outside USA)
Nieuwegein, Netherlands Phone : +31 (0) 30 248-1193
München, Germany Phone : +49 (0) 89 4357 156 0
Roissy CDG, France Phone : +33 (0) 1 80 11 10 70
Warrington, United Kingdom Phone : +44 (0) 1925 467300
Cinisello Balsamo, Italy Phone : +39 02849488.00
Dietikon, Switzerland Phone : +41 (0) 43 322-9800
Vastra Frölunda, Sweden Phone : +46 (0) 31 7099464
Wroclaw, Poland Phone : +48 (0) 71 73452-11
Shanghai, China Phone : +86- (0)21-5489 0202
Beijing, China Phone : +86- (0)10-8522 1551
Guangdong, China Phone : +86- (0)20-3826 4220
Chongqing, China Phone : +86- (0)23-6773 4988
Shandong, China Phone : +86- (0)532-8079 1871
Hubei, China Phone : +86- (0)27-8544 9942
Singapore Phone : +65 6563-5533

Fax : 201-785-2482
+31 (0) 30 248-1280
+49 (0) 89 4357 156 99
+33 (0) 1 80 11 10 82
+44 (0) 1925 711143
+39 02849488.30
+41 (0) 43 322-9809
+48 (0) 71 734 52 10
+86- (0)21-5489 0005
+86- (0)10-8522 1241
+86- (0)20-3826 4223
+86- (0)23-6773 4799
+86- (0)532-8079 1873
+86- (0)27-8544 9991
+65 6560-9721

Konica Minolta (CHINA) Investment Ltd.
Konica Minolta Sensing Singapore Pte Ltd.



Certificate No.: LRQ 0960094A
Registration Date: March 3, 1985



Certificate No.: JQA-E-80027
Registration Date: March 12, 1997

Konica Minolta Sensing Korea Co., Ltd.
Konica Minolta, Inc.

Sensing Business
Thailand Representative Office

Goyang-si, Korea
Bangkok, Thailand

Phone : +82(0)2-523-9726
Phone : +66-2361-3730

Fax : +82(0)31-995-6511
Fax : +66-2361-3771

Addresses and telephone/fax numbers are subject to change without notice. For the latest contact information,
please refer to the KONICA MINOLTA Worldwide Offices web page :

©2015 KONICA MINOLTA, INC.

<http://konicaminolta.com/instruments/network>

9242-4876-14 BFHPK Printed in Japan